

United States Patent

Diersbock

[15] 3,638,419

[45] Feb. 1, 1972

- [54] **HOROLOGICAL HAIRSPRING REGULATOR**
- [72] Inventor: **Gunther Rudolph Diersbock**, Waterbury, Conn.
- [73] Assignee: **Timex Corporation**, Waterbury, Conn.
- [22] Filed: **Mar. 22, 1971**
- [21] Appl. No.: **126,741**

3,517,503 6/1970 Smythe, Jr. et al.58/109
 3,564,840 2/1971 Meitinger58/109

Primary Examiner—Stephen J. Tomsky
Assistant Examiner—Stanley A. Wal
Attorney—Richard A. Joel

- [52] U.S. Cl.58/109
- [51] Int. Cl.G04b 17/14
- [58] Field of Search58/109, 113, 85.5, 26 R, 26 B

[57] **ABSTRACT**

A horological instrument includes an oscillator assembly and a hairspring. The hairspring is fastened at one end to the oscillator assembly and is anchored to the frame or bridge at its opposite end. A regulator includes two spaced apart arms having slots which surround the hairspring. The regulator is designed to impart a positive isochronism characteristic to the hairspring in order to permit synchronizing of the balance wheel motor. The frequency of balance oscillation is thus made dependent on amplitude of oscillation.

[56] **References Cited**

UNITED STATES PATENTS

- 2,183,062 12/1939 Conrad.....58/26 B
- 2,307,841 1/1943 Marti.....58/113

6 Claims, 7 Drawing Figures

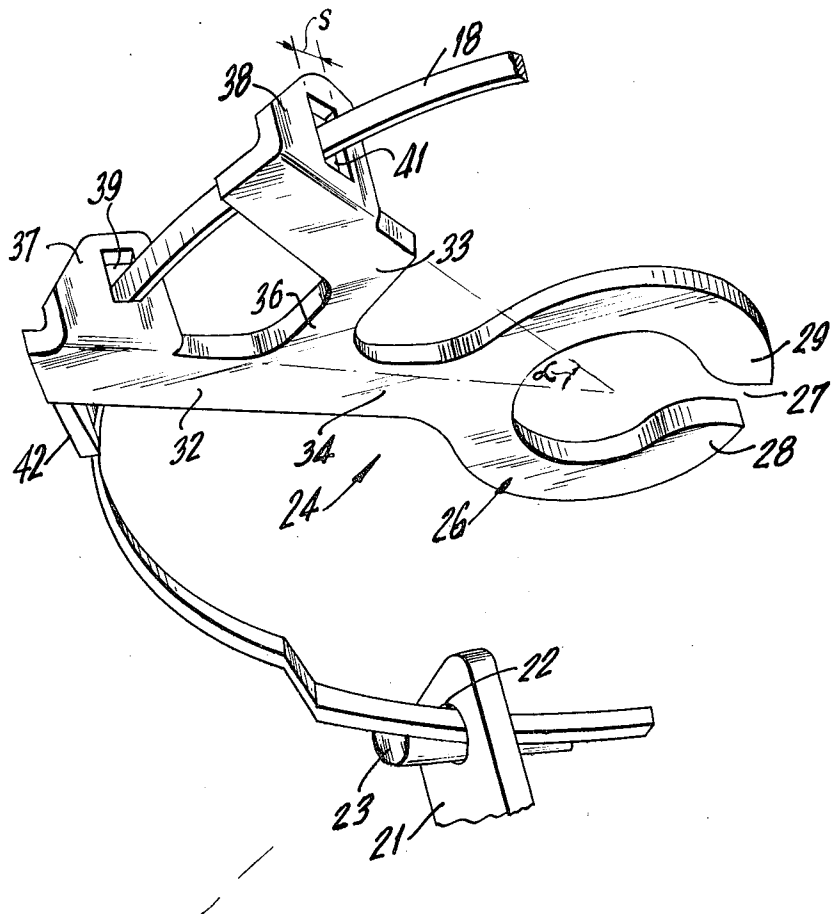

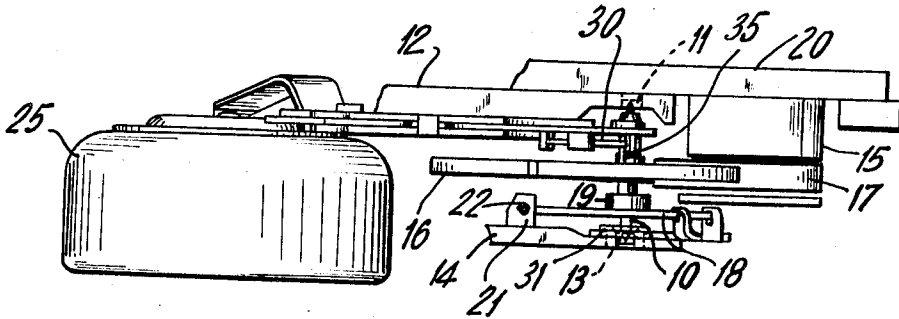

FIG. 1

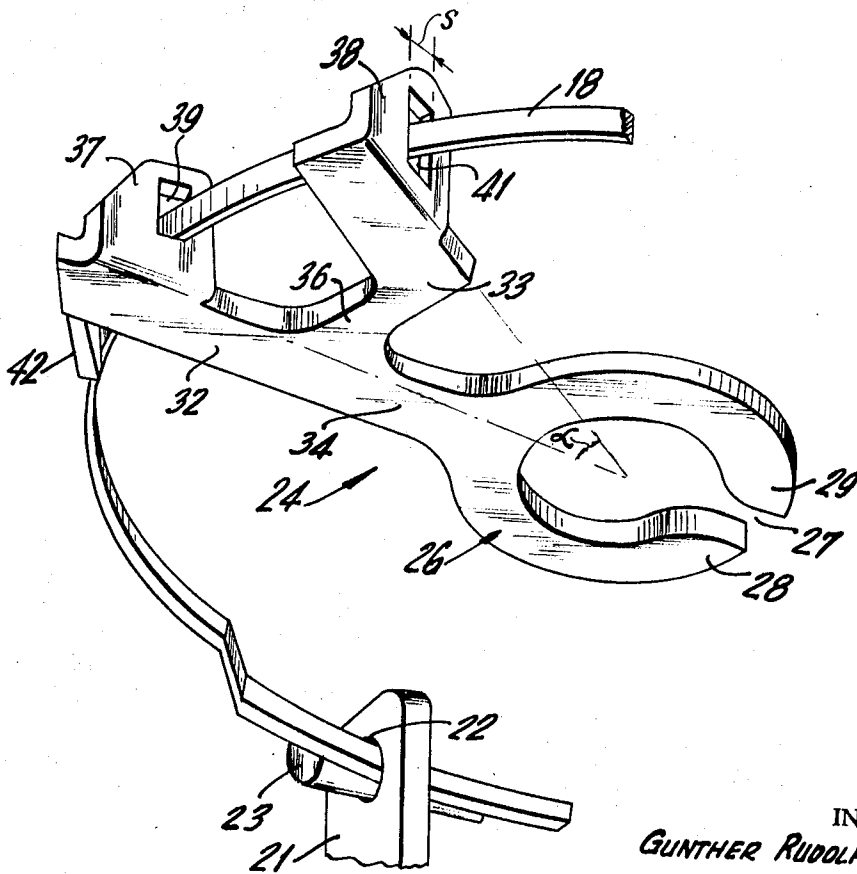

FIG. 2

INVENTOR.
GUNTHER RUDOLPH DIERSBOCK
BY

Richard A. [Signature]
ATTORNEY

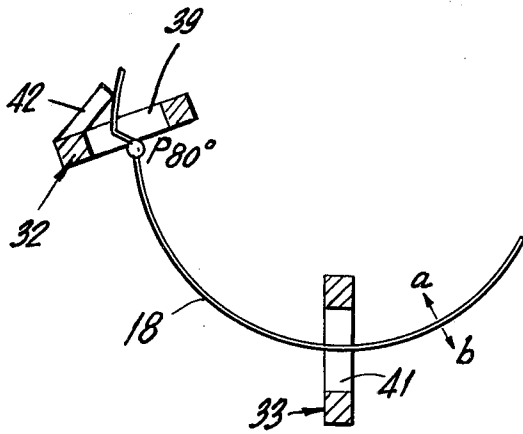

FIG. 5

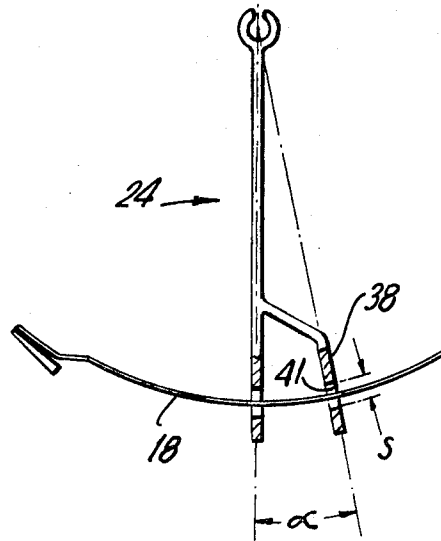

FIG. 3

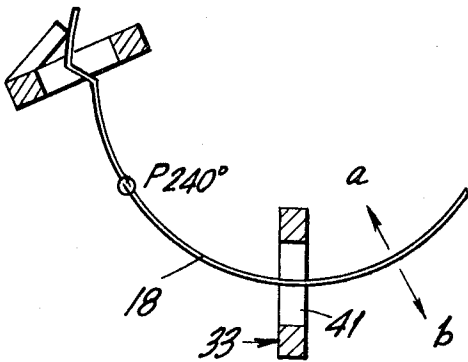

FIG. 6

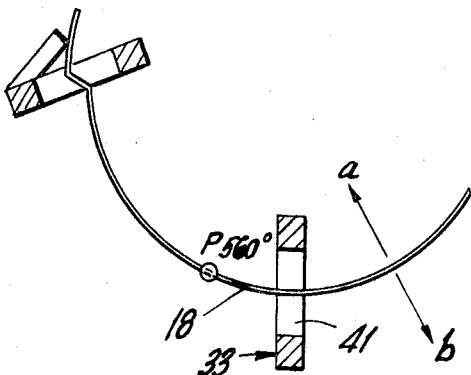

FIG. 7

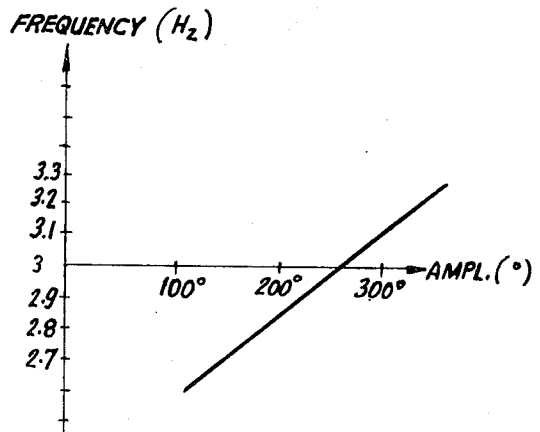

FIG. 4

INVENTOR.
GUNTHER RUDDLPH DIERSBOCK
BY

Richard A. Josef
ATTORNEY

HOROLOGICAL HAIRSPRING REGULATOR

BACKGROUND OF THE INVENTION

The present invention relates to horology and more particularly to a regulator for timepieces.

The use of regulators in timepieces is conventional and many watch designs include regulators which contact the hairspring to vary the effective length thereof. During the life of a watch, the regulator may be adjusted to maintain the timekeeping characteristics by increasing or decreasing the active length of the spiral hairspring. Among the various prior art references, most of which are directed to particular problems, are U.S. Pat. Nos. 2,307,841; 2,482,351 and 3,517,503 and Swiss Pat. No. 338,770.

U.S. Pat. No. 2,183,062 to F. Conrad discloses a regulator which includes two widely spaced prongs. The balance wheel shaft is thus caused to oscillate by a hairspring which is deliberately designed not to keep good time. A synchronization system is also employed.

The above are merely illustrative of the prior art and other patents may exist and be pertinent to the present invention.

SUMMARY OF THE INVENTION

The present invention relates to a regulator for imparting a positive isochronism characteristic to the oscillator of a watch. By means of the regulator, the frequency of balance oscillation is made dependent on amplitude of oscillation. This facilitates synchronization of the balance wheel particularly by a quartz controlled time standard.

The regulator comprises a base portion which is rotatably mounted to the bridge and two arms, each of which include downwardly extending flange portions with openings to accommodate the hairspring. The first regulator arm which includes a side portion in contact with the hairspring is used to position the hairspring in the center of the slot of the second regulator arm and to vary the effective length of the hairspring. The hairspring vibrates within the slot in the second regulator arm. The angle between the two regulator arms and the width of the slot in the second regulator arm are designed to produce the desired isochronism characteristic.

Accordingly, it is an object of this invention to provide a new and improved regulator for synchronized timepieces.

Another object of this invention is to provide a unique regulator for imparting a positive isochronism characteristic to an oscillator which isochronism characteristic will not be disturbed by moving the regulator.

Other objects and advantages of the present invention will be more clearly seen when viewed in conjunction with the accompanying drawings wherein:

FIG. 1 is side view of the balance assembly and regulator comprising the present invention;

FIG. 2 is a perspective view of the regulator of the present invention;

FIG. 3 is a schematic view of the subject regulator;

FIG. 4 is a graph illustrating a typical isochronism characteristic effected by the present invention; and

FIGS. 5-7 illustrated schematically the operation of the subject regulator.

DETAILED DESCRIPTION OF THE INVENTION

The positioning of a regulator within a watch particularly with relation to the balance wheel assembly is well known and hence not disclosed in detail herein. The prior art mentioned above does show typical regulator arrangements in a watch and it would be within the knowledge of one skilled in the art to assemble the regulator thereto on the basis of the present disclosure.

Referring now to the drawings, the balance staff 10 is journaled at one end in a bearing 11 on the front frame 12. The other end of the staff 10 is journaled in bearing 13 on the balance bridge 14. The balance wheel 16 is mounted to the staff 10 and may include a coil 17 mounted thereon for oscillation past stationary magnets 15 attached to the dial ring 20.

A hairspring 18 is mounted to the hub 19 and is also affixed to the bracket 21. The hairspring 18 is inserted through the aperture 22 in bracket 21 and mounted firmly thereto by tapered pin 23. The hairspring 18 which may be a conventional spring is used to store the kinetic energy of the balance wheel 16 during oscillation. The movement itself is powered by cell 25 which transmits power through contact spring 30 to contact pin 35 on the balance wheel 16.

The regulator 24 comprises an end portion or base 26 having a substantially circular configuration with a gap 27 between the respective portions 28 and 29. The portions 28 and 29 are spread apart for mounting on hub 31 which is located on balance staff 10. The regulator 24 is mounted parallel to and slightly above the hairspring 18 in the watch assembly.

The other end of the regulator 24 comprises a pair of arms 32 and 33, which are spaced apart a predetermined distance along the arc of a circle corresponding to the hairspring 18. Another way of stating the spacial relationship of the arms 32 and 33 is to specify the angle between the arms. The arm 32 runs directly off the body portion 34 while arm 33 is joined thereto by a bridge portion 36 which is positioned at an angle to the body 34.

Regulator arms 32 and 33 each include an upwardly extending flange portion 37 and 38 respectively having respective slots 39 and 41 extending therethrough. Arm 32 includes a projecting portion 42 which is located before the slot 39 and contacts the hairspring 18 to limit the effective length thereof. The other purpose of arm 33 is to position the hairspring 18 in the center of slot 41. The hairspring 18 normally vibrates within the slot 41 in a manner to be described hereinafter.

In designing the regulator 24, the angle α and the width s of the slot 41 are selected to provide the desired isochronism characteristic. By taking a conventional hairspring 18 and modifying its characteristics by means of regulator 24, it is possible to obtain a relationship wherein the frequency of balance oscillation is made dependent on the amplitude of oscillation. The typical isochronism characteristic achieved by regulator 24 which is illustrated in FIG. 4, differs from the normal design wherein frequency would be independent of amplitude. This facilitates synchronization of the balance wheel 16 particularly in quartz type watches.

During the operation of the timepiece, the regulator 24 functions on the hairspring 18 in the manner shown in FIGS. 5-7. Referring to FIG. 5 at small amplitudes, for example 80°, the hairspring 18 will vibrate between positions a and b and will not touch the regulator arm 33 as it moves back and forth within the slot 41. The effective length of the hairspring 18 is from the inner point to the theoretical outer pinning point (P 80°). The balance wheel will oscillate at a low frequency. The low frequency as may be seen from the graph of FIG. 4.

Referring to FIG. 6, at larger amplitudes (240°) the hairspring 18 will vibrate between positions a and b and rest for about 40 percent of the period on the regulator arm 33. Effective length of the hairspring will be from inner pinning point to the theoretical outer pinning point (P 240°). The frequency of the balance wheel will thus increase.

Referring to FIG. 7, at a further increase in amplitude to 560° the hairspring 18 will vibrate between positions a and b and will rest for approximately 80 percent of the period on the regulator arm 33. The effective length of the hairspring 18 is from the inner pinning point to the theoretical outer pinning point (P 560°) which results in a further increase in balance motor frequency.

An important advantage of the subject regulator 24 is that the isochronism characteristic will not be disturbed by regulating the timepiece since the angle α and the slot width 41 always remain constant. With the increasing emphasis on accuracy and the use of quartz synchronized systems to attain such accuracy, the regulator 24 proposed herein permits unique advantages.

It is to be understood that the above-described arrangements are merely illustrative examples of the application of

3

4

the principles of the invention. Numerous other arrangements may be readily devised by those skilled in the art which will embody the principles of the invention and fall within the spirit and scope thereof.

I claim:

1. In a timepiece having a balance wheel assembly and a hairspring coupled thereto, a regulator which comprises:

a base portion for mounting to the balance wheel assembly; and

a pair of arms extending outwardly from the base portion, each of said arms having a downwardly extending flange with an opening therethrough to accommodate the hairspring and to impart a predetermined positive isochronism characteristic thereto.

2. A regulator in accordance with claim 1 wherein: the regulator arms are spaced apart at a predetermined angle which remains constant.

3. A regulator in accordance with claim 2 wherein: the flange of the first regulator arm includes a portion which contacts the hairspring in order to position the hairspring normally in the opening of the second regulator arm

flange and limit the effective length of the hairspring.

4. A regulator in accordance with claim 2 wherein: the width of the opening in the second flange is a predetermined dimension so that as the hairspring vibrates the effective length thereof will be such that the frequency of the balance oscillation is dependent on amplitude of oscillation.

5. A regulator in accordance with claim 2 wherein: the base portion includes a bifurcated design having a substantially circular configuration.

6. In a timepiece having a balance wheel motor and hairspring, a regulator comprising:

first means engaging the hairspring to limit the effective length thereof, and

second means located at a predetermined constant angle from the first means and having a slot therein of constant dimension to be engaged by the hairspring, said second means in combination with said first means imparting a positive isochronism characteristic to the hairspring which will not be disturbed by moving the regulator.

* * * * *

25

30

35

40

45

50

55

60

65

70

75